

diaphragm seal for DS 2.5" (63mm) pressure gauges, with threaded connection

MGS9/367



Diaphragm seals are designed to isolate the sensing element of pressure gauges DS 63 and electronic transmitter from process fluids which may be corrosive, viscous, sedimentous and /or with a high temperature. The diaphragm is welded to the top housing and leak proof tested, to guarantee a separation between process fluid and fill transmission fluid. This construction feature and its compact design suits many application that require frequent maintenance.

4.367 - MGS9/367

Working pressure : *from 0...600 to 0...6000 psi (from 0...40 to 0...400 bar).*

Process temperature: *-49...+302°F (-45°C...+150°C).*

Accuracy*: (add to instrument accuracy) $\pm 1\%$ for direct mounting only.

Diaphragm: welded,

4 - AISI 316 L st.st.

Process connection:

4 - AISI 316 st.st.

Filling liquid: silicone oil.

* at 68°F (20 °C) process temperature (or state temperature when ordering)

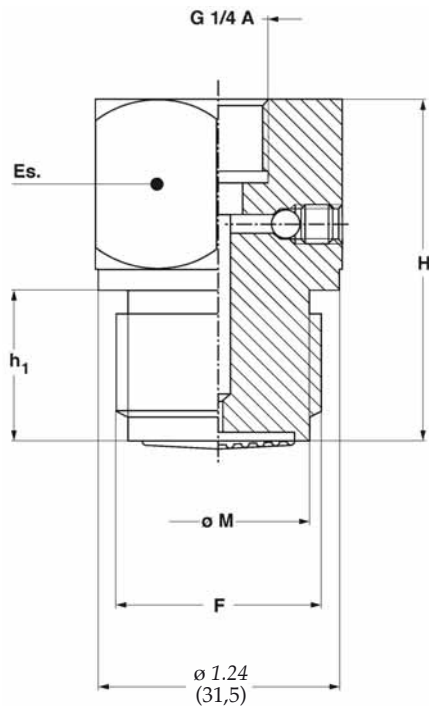

F	M	h ₁	H	Es.
51M	0.92"	0.62"	1.43"	1.25"
G 3/4 M	(23,5)	(16)	(36,5)	(32)

dimensions : inches (mm)

ASSEMBLING

D - All diaphragm seals are mounted directly on the instruments.

OPTIONS

B -	Silicon liquid "B" for process fluid temperature from -4°F to +482°F (from -20°C to +250°C)
C -	Silicon liquid "C" for process fluid temperature from +68°F to +644°F (from +20°C to +340°C)
E -	Fluorinated liquid "E" for process fluid temperature from -76°F to +302°F (from -60°C to +150°C)
C05 -	Helium Test
P04 -	Dye penetrant test

"HOW TO ORDER" SEQUENCE

Section/Model/Connection material/Diaphragm material/Process Connection/Instrument connection/Assembling/Options
4 **367** **4** **4** **51M** **21F - G 1/4 F** **D** **B...P04**